



UNIVERSITY OF
CAMBRIDGE
Institute for Manufacturing

Automating EPC: The Role of EPC in Supply Chain Control

Duncan McFarlane
Research Director
– Cambridge Lab





INFORMATION INTO ACTIONS

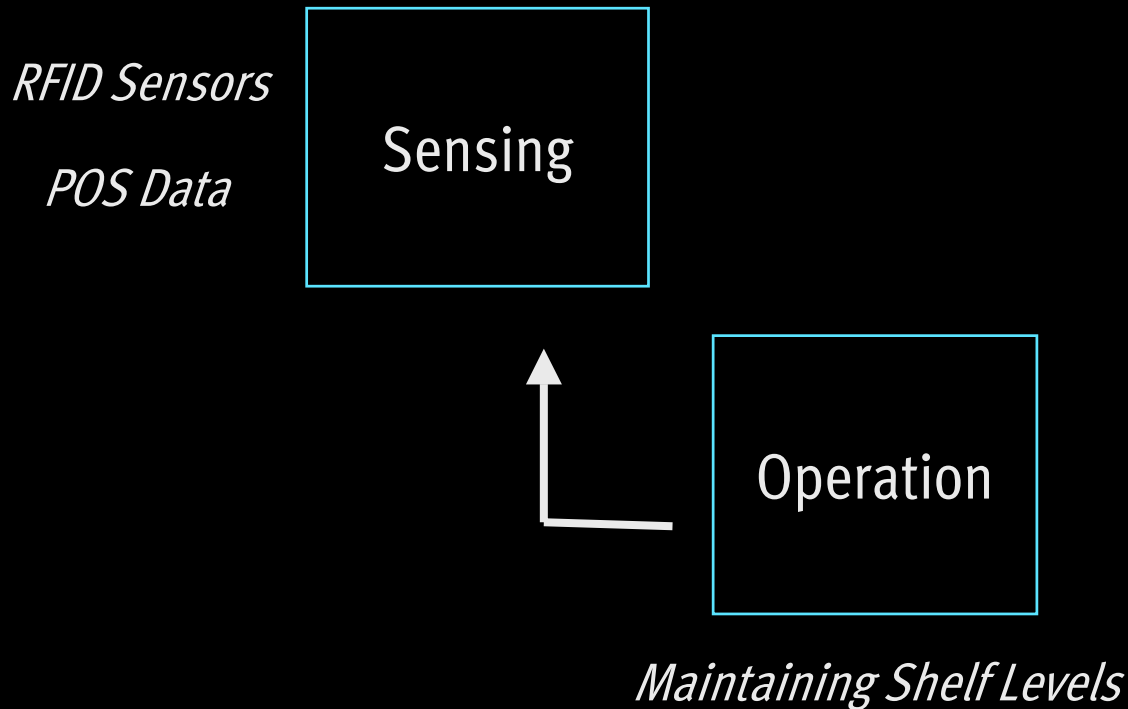



INFORMATION INTO ACTIONS

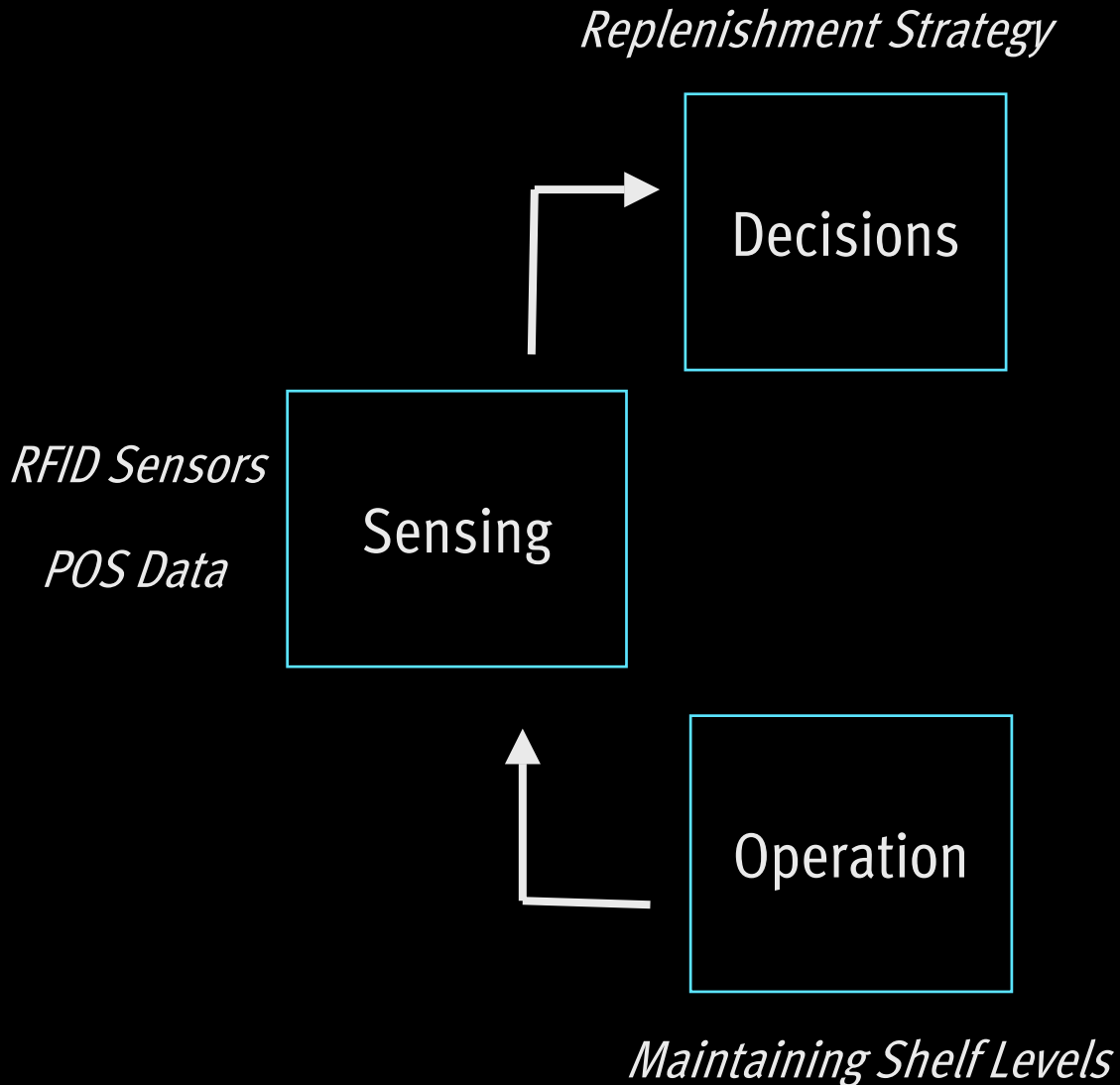



INFORMATION INTO ACTIONS

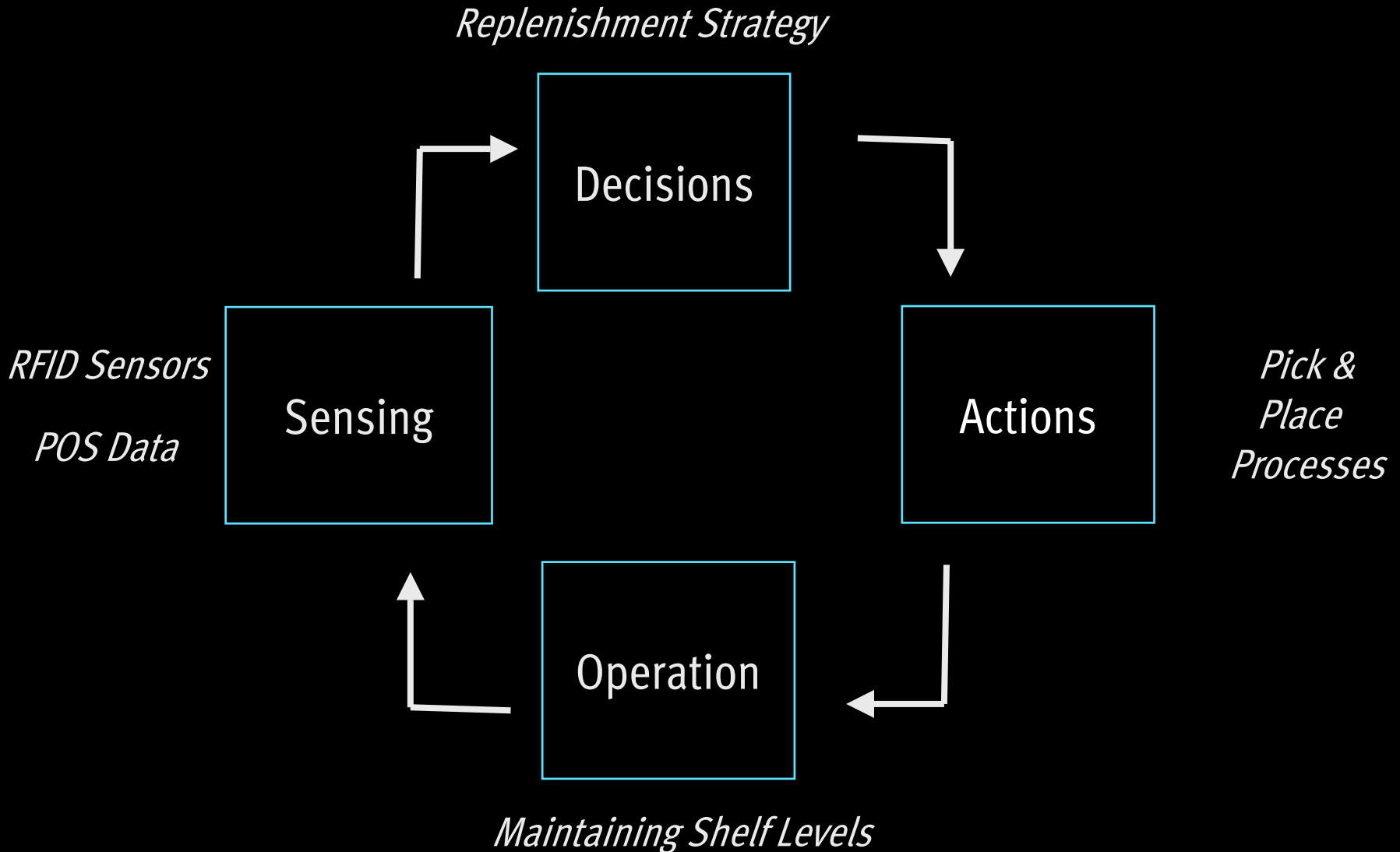



INFORMATION INTO ACTIONS

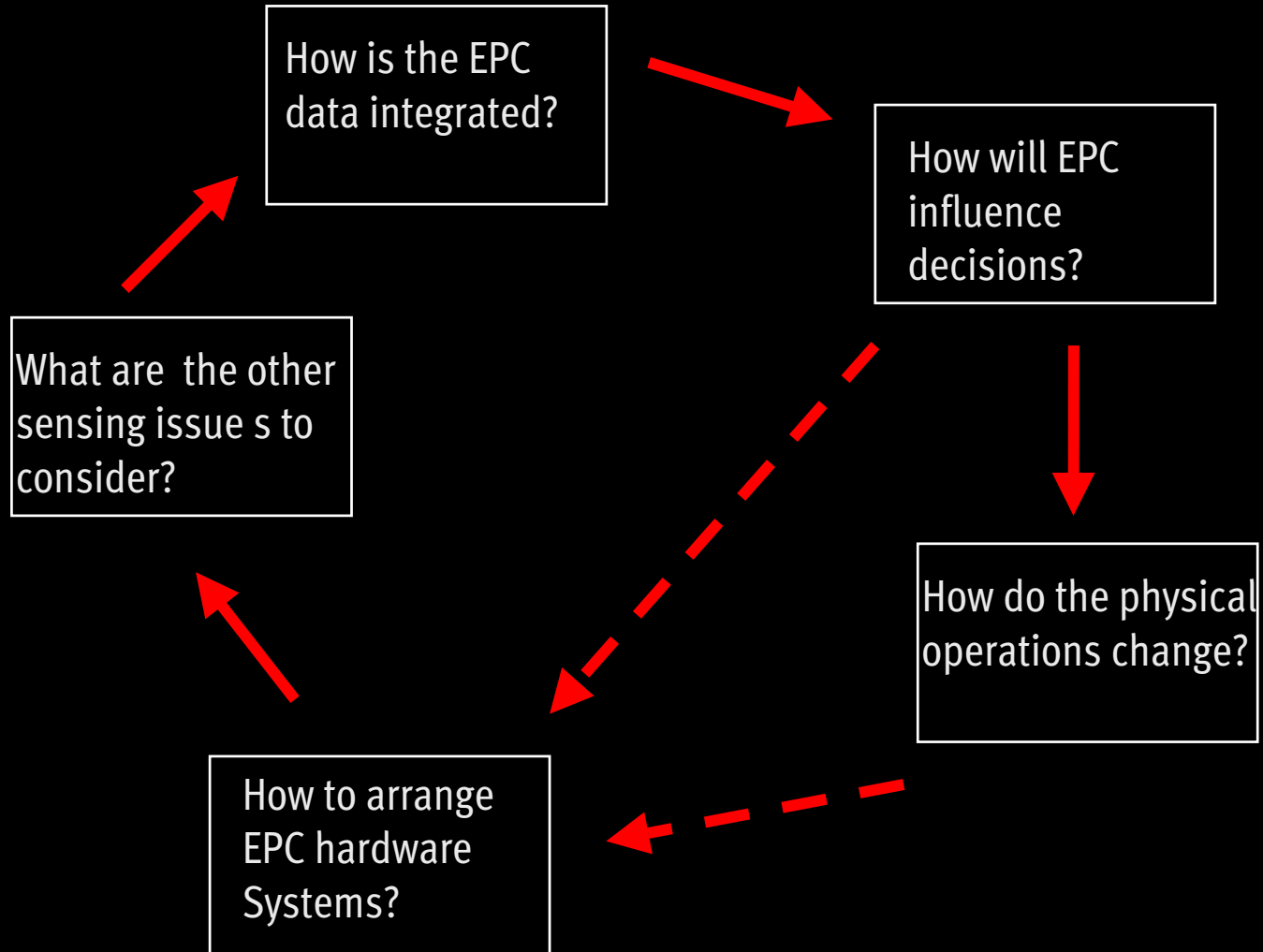



- Arranging EPC hardware
- Other Sensing Requirements
- Integrating EPC Data
- Influencing Decisions
- Enhancing Physical Operations



- Arranging EPC hardware
- Other Sensing Requirements
- Integrating EPC Data
- Influencing Decisions
- Enhancing Physical Operations



ARRANGING EPC HARDWARE

- Technological issues impact on hardware
 - Read ranges
 - Communications capacity
 -
- BUT Operational needs are the real driver for an EPC solution configuration
- Desired “Visibility” is a relative term dependent on decisions and operations needed





ARRANGING EPC HARDWARE

- **Visibility In Space** - ability to distinguish between locations of item

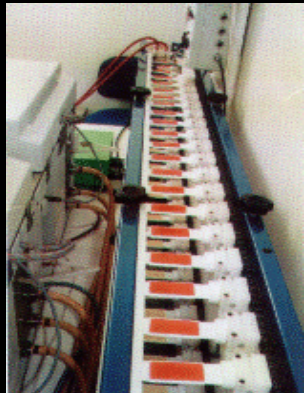

- **Visibility In Time** - ability to distinguish between items at different times

- **Visibility In Identity** - ability to distinguish between items with different identity





ARRANGING EPC HARDWARE

Guidelines:

- Determine which decisions / operations are dependent on the availability of EPC data?
- For each decision assess Reads/sec/m²
- determine:
 - How many readers/antennae?
 - Acceptable Reader ranges / accuracy / frequency/reliability?
 - Where to locate readers / antennae?





- Arranging EPC hardware
- **Other Sensing Requirements**
- Integrating EPC Data
- Influencing Decisions
- Enhancing Physical Operations



OTHER SENSING REQUIREMENTS

- an RFID based EPC Solution provides
 - Item ID
 - Size
 - History
 - Instructions
 - *Coarse* product Location Information
- an RFID based EPC Solution DOESN'T provide
 - Accurate product location
 - orientation
 - Other sensory information: temperature, humidity
- Location / identity synchronisation particularly critical

OTHER SENSING REQUIREMENTS

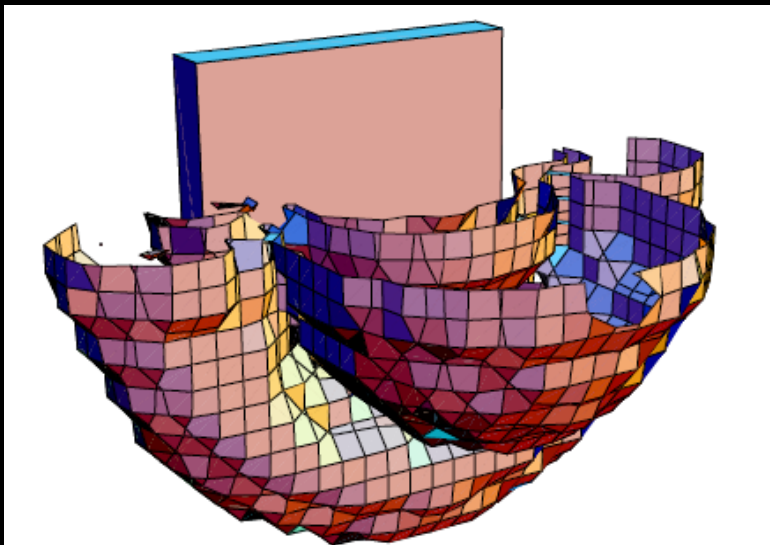
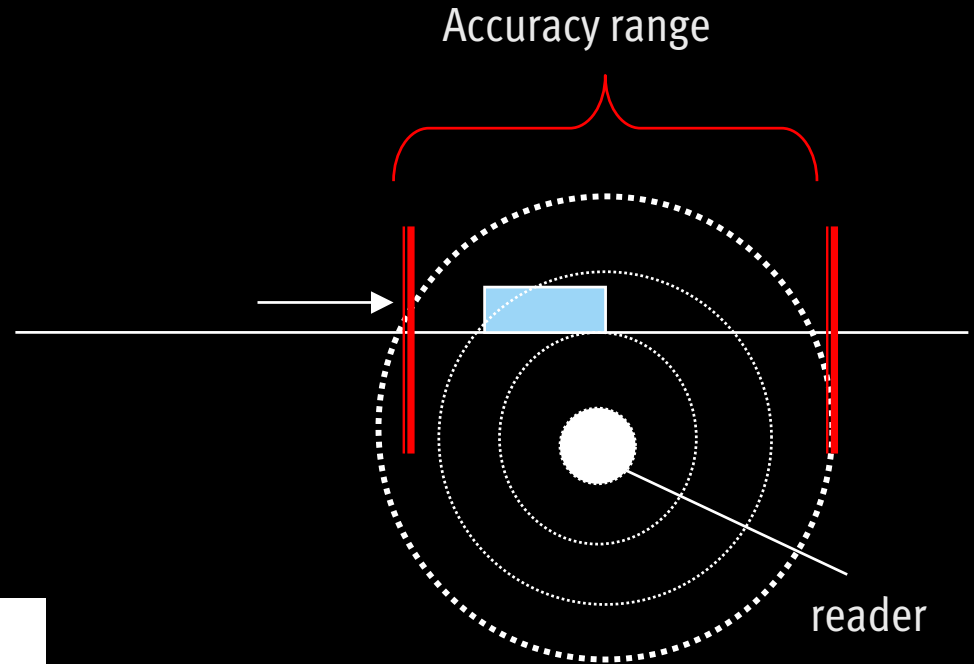

- + Proximity sensors
- Cameras
- Tracking models
- Physical constraints



OTHER SENSING REQUIREMENTS

Guidelines: (Location)

- Determine fixed conditions of operation (line speed, shelf spacing)
- Establish location accuracy requirements
- Assess whether RFID alone can deliver
 - Constrain physical movement
 - Create physical movement
 - Use additional position sensing
- Establish auxiliary sensory needs and coordinate collection with EPC system



- Arranging EPC hardware
- Other Sensing Requirements
- **Integrating EPC Data**
- Influencing Decisions
- Enhancing Physical Operations



INTEGRATING EPC DATA

Product



- Application type?
- Real Time?
- EPC Data required (EPC / PML)
- Existing IT infrastructure



Business

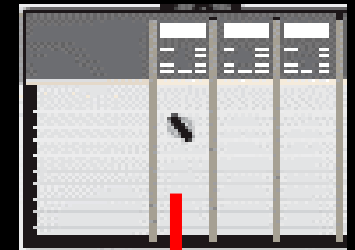

Operations





INTEGRATING EPC DATA

Manufacturing Case Study

- multiple data streams
- multiple destinations
- multiple actions

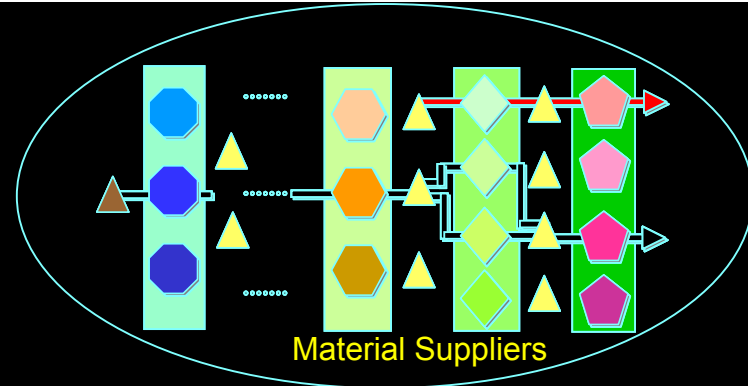

Shop floor information
(e.g. WIP, inventory,
shop orders movements)

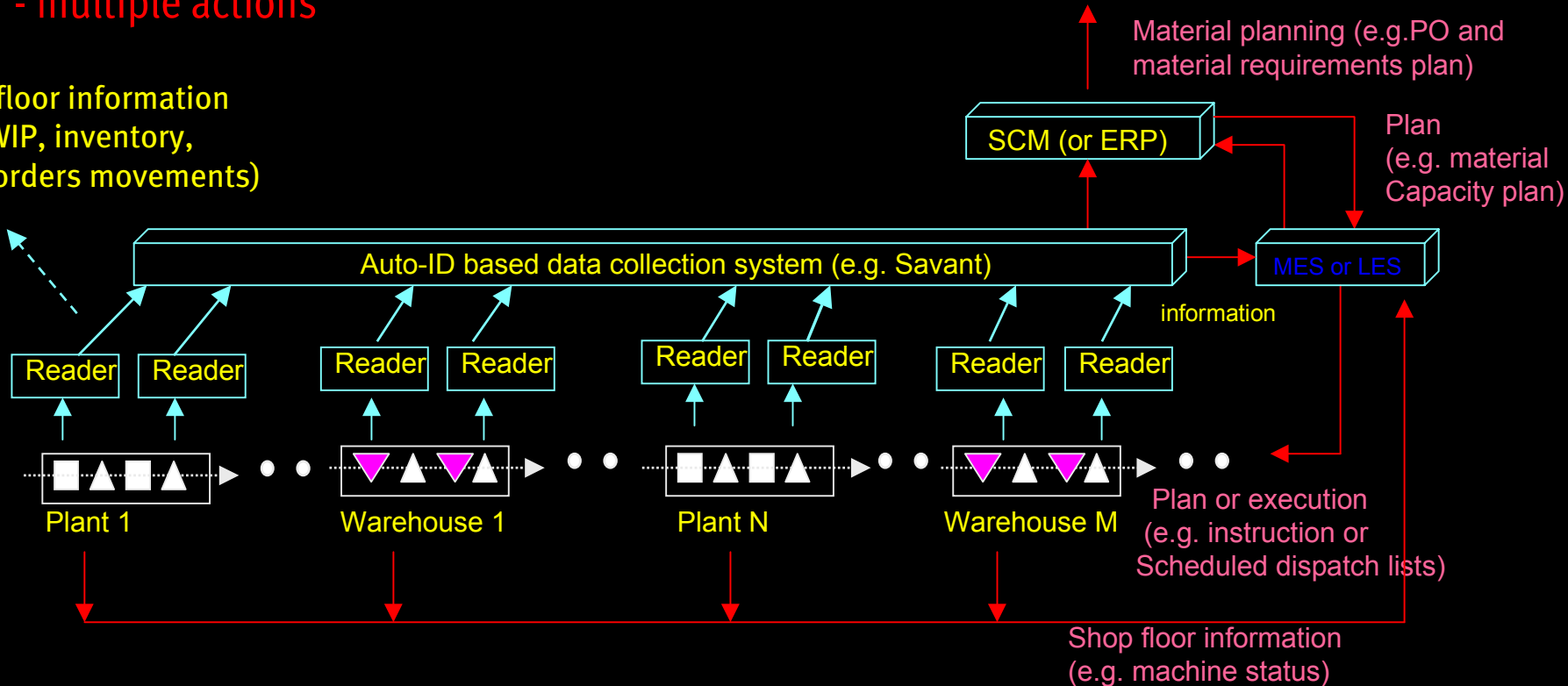



INTEGRATING EPC DATA

Guidelines:

- Determine applications requiring EPC data
- For each
 - RT/non RT
 - Control / Monitor
 - Classify EPC data type
- Build Use Cases
- Establish EPC system processing needs
- Establish IT systems interface to EPC data stream



- Arranging EPC hardware
- Other Sensing Requirements
- Integrating EPC Data
- **Influencing Decisions**
- Enhancing Physical Operations



INFLUENCING DECISIONS

Using EPC data to create improvements in Supply Chain Decision making processes (Ordering, Planning, Scheduling, Inv Management)

- more timely/accurate product data:
 - => e.g. more dynamic response
- high fidelity:
 - => e.g. improves capability for customisation
- increased data “range”:
 - => e.g. use full life cycle information



INFLUENCING DECISIONS

Late Customised Manufacturing:
Towards the interactive customer order

- order generates network connection to materials
- order escorts product through production
- order expresses preferences / priorities

INFLUENCING DECISIONS

“Ideal” EOL Decisions

- Collection
- Sorting
- EOL Option
- Disassembly
- Disposal

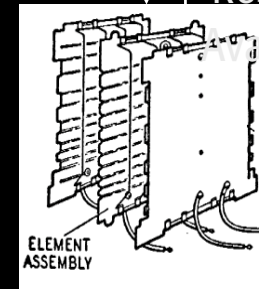
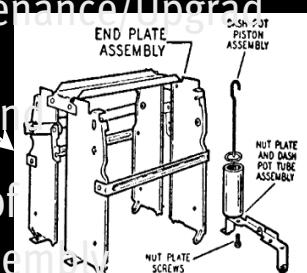
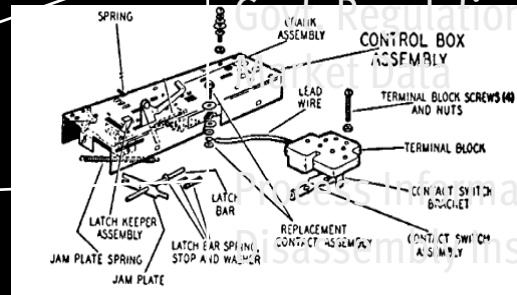
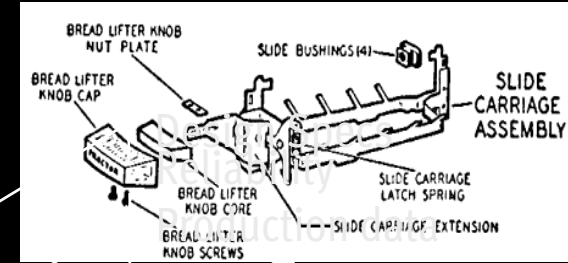
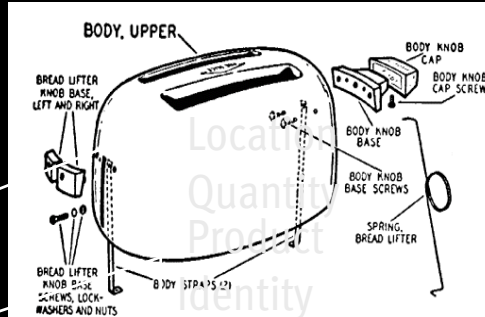

Product Quality

Govt. Regulations
Material Information

Usage

Maintenance/Upgrade

Demand

Price
Cost of

disassembly

Resource

Availability

Instructions

Govt. Regulations

Material Information

Product Quality

Govt. Regulations

Material Information

Product Quality

Govt. Regulations

Material Information

Product Quality

Govt. Regulations

Material Information

Product Quality

Govt. Regulations

Material Information

Product Quality

Govt. Regulations

Material Information



INFLUENCING DECISIONS

Guidelines:

- Consider proposed EPC system with existing decisions
- Identify potential opportunities for improving efficiencies, flexibilities
- Adapt decision processes & evaluate
- Re assess EPC hardware configurations



- Arranging EPC hardware
- Other Sensing Requirements
- Integrating EPC Data
- Influencing Decisions
- **Enhancing Physical Operations**



ENHANCING THE PHYSICAL OPERATIONS

- The facilities myth
orderly = efficient!
- Excess buffering / time delays / slack periods to add resilience
- Opportunities for increasing flexibilities not fully exploited



RETAIL SHELF REPLENISHMENT

Issue:

Analysis of the impact of accurate and timely item level information on shelf replenishment policies

Approach:

Dynamic retailer simulator

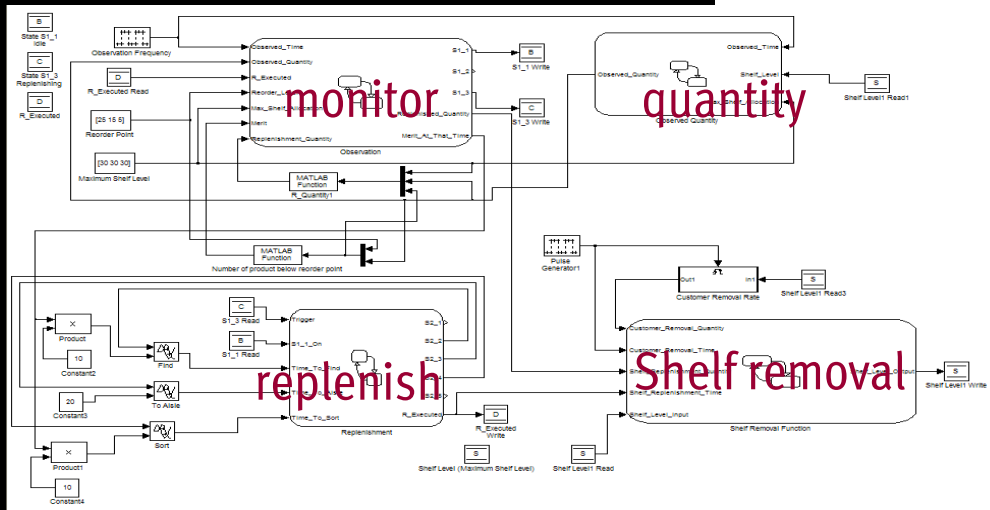
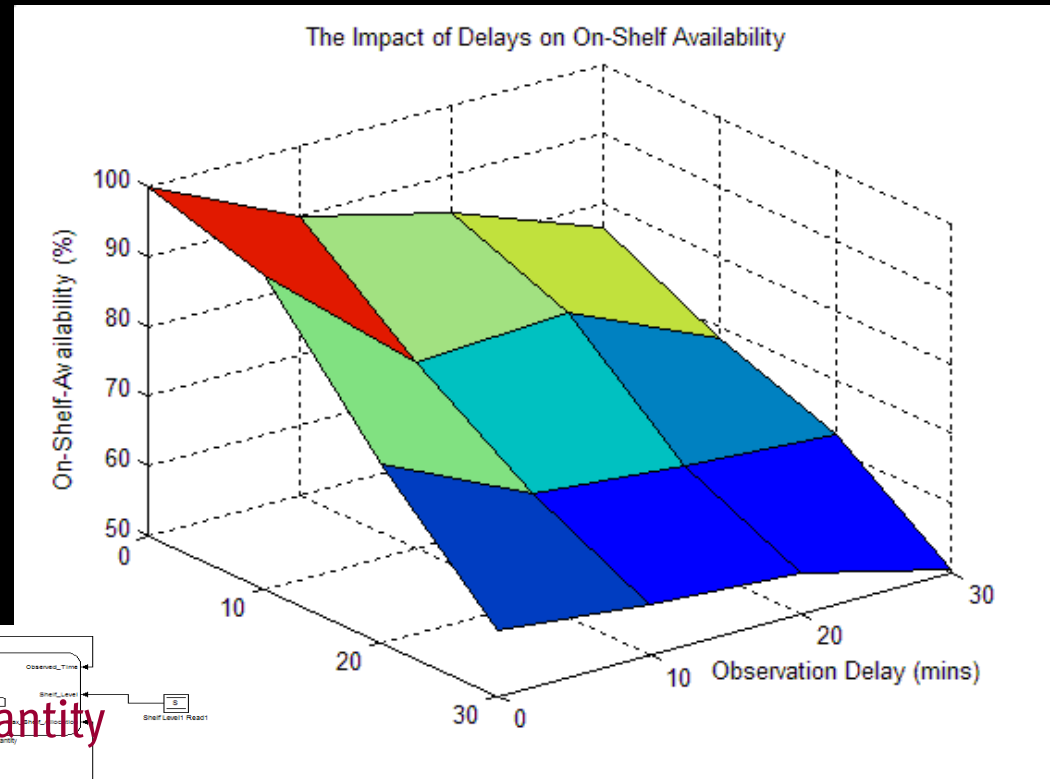



ENHANCING THE PHYSICAL OPERATIONS

Warehouse space
optimisation

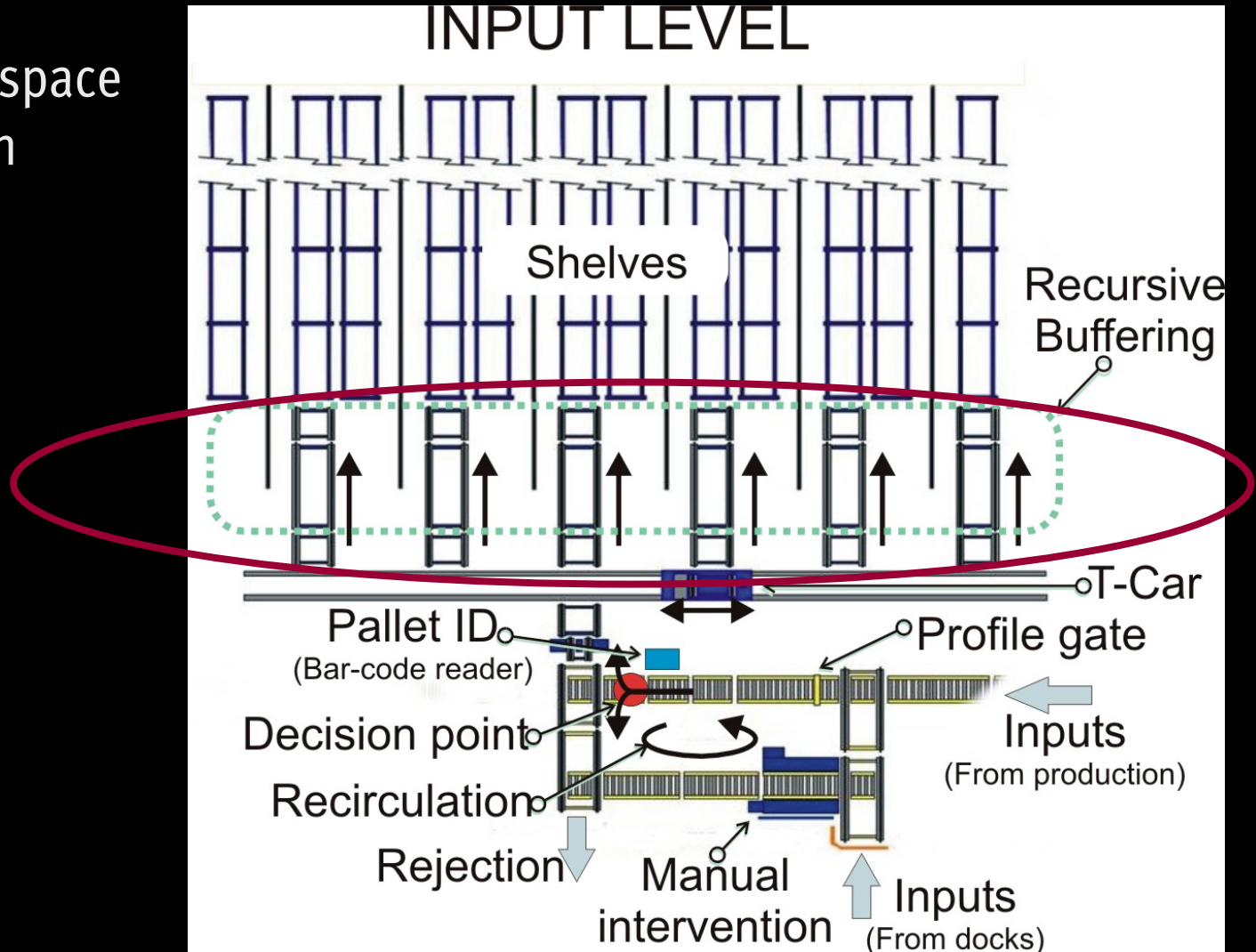



ENHANCING THE PHYSICAL OPERATIONS

Guidelines:

- Consider proposed EPC system with existing decisions
- Identify potential opportunities for
 - Reducing buffering / delays / slacks
 - improving flexibilities
- Adapt physical processes & evaluate
- Re assess EPC hardware configurations



MINI SUPPLY CHAIN DEMONSTRATION

Auto ID Lab – Cambridge University

Auto ID Driven Supply Chain Demonstration



MINI SUPPLY CHAIN DEMONSTRATION

- EPC Hardware: reader locations at gates / loading / storage
- Location/Orientation Sensing: proximity sensors / fixtures / casing
- IT Integration: EPCs for control / PML for order management
- Decisions: Dynamic order planning, latest commitment scheduling, flexible control
- Physical Layout: flexible routing / distributed storage



MINI SUPPLY CHAIN DEMONSTRATION





MINI SUPPLY CHAIN DEMONSTRATION

packing





MINI SUPPLY CHAIN DEMONSTRATION

recall





MINI SUPPLY CHAIN DEMONSTRATION

- EPC Hardware: reader locations at gates / loading / storage
- Location/Orientation Sensing: proximity sensors / fixtures / casing
- IT Integration: EPCs for control / PML for order management
- Decisions: Dynamic order planning, latest commitment scheduling, flexible control
- Physical Layout: flexible routing / distributed storage



INFORMATION INTO ACTIONS

- EPC deployment goes beyond installing basic building blocks
- systematic approach needed to integrating EPC systems
- Deployment is not necessarily a linear process
- Consider two phases of deployment
 - Existing systems
 - New Business Processes
- Value is yet to be fully identified in manufacturing